

### Features

- ⊕ PJ 77 without switch
- ⊕ PJ 78 with built-in On/Off switch
- ⊕ CW or CCW switch position
- ⊕ Durable tampon-printed numbering, various types
- ⊕ Different knobs available, for both ITE/BTE
- ⊕ Different axles available
- ⊕ Different terminal lengths available
- ⊕ Different plastic colors available
- ⊕ Adaptor rings available
- ⊕ Accurate tapers. Linear, logarithmic, double logarithmic and custom-made
- ⊕ Customized resistance values and tolerances

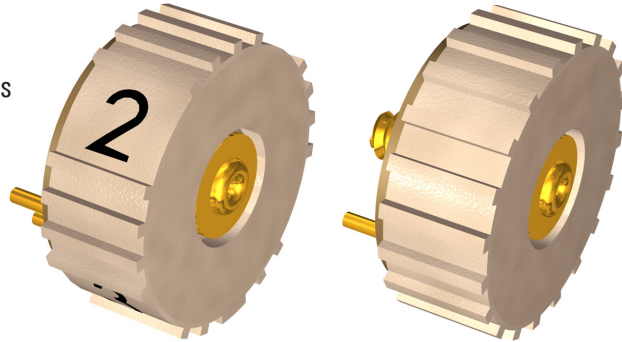

### Contents

	Page
History Revision .....	2
Mechanical Specifications .....	3
Electrical Specifications .....	3
Material Specifications .....	3
Environmental Conditions .....	4
Recommended Process Parameters .....	4
Mechanical Dimensions .....	5
Knob Styles .....	6
Knob Prints .....	8
Cap Styles .....	9
Axle Styles .....	11
Terminal Length .....	12
Adaptor Ring Styles .....	13
Plastic Colors .....	13
Color Coding .....	14
Knob .....	14
Product Specification Form .....	15

Sonion reserves the right to make changes at any time to improve reliability, function or design, in order to provide the best product possible.

### History Revision

Revision Number/Date	Change from last revision
06 / Aug. 03	History Revision added. Switch lead corrected to 1.5 mm. Knob Style No. 02 and Axle Style No. 07 and 10 have been corrected. Plating material changed.
07 / Feb. 04	Rotational torque changed
08 / Apr. 08	Storage humidity added. Operational temperature and humidity removed. New lay-out. New data sheet design
09 / May 08	Housing material removed
MT1038.A (07/08)	Minimum resistance value on linear tapers increased to 200 $\Omega$ .
010/JUL-14-2009	No technical updates
011/SEP-29-2009	Knob Styles Nos. 03, 04, 05, 06, 07, 17, 18, 60, 61, 62, 71, 72 and 73 Cap Styles Nos. 04, 05 and 07 removed
012/OCT-29-2009	Resistance curve angle corrected

### Mechanical Specifications

Rotational angle, mechanical.....	260° ±3°
Resistance curve angle.....	220°
PJ 78 switch angle.....	20°
End stop torque.....	Min. 300 cNcm
Rotational torque.....	Min. 3 cNcm, max. 8 cNcm
PJ 78 switch operating torque.....	Min. 20 cNcm, max. 50 cNcm
Terminal retention force.....	Min. 10 N

#### Lifetime:

-Resistance element.....	Min. 25,000 cycles
-PJ 78 On/Off switch.....	Min. 15,000 cycles

### Electrical Specifications

#### Resistance value:

-Linear.....	200 Ω to 1 MΩ
-Logarithmic.....	500 Ω to 600 kΩ
-Double logarithmic.....	2 kΩ to 500 kΩ
Resistance value tolerance.....	±20% (-20% to +30% for values ≤ 1 kΩ)
Resistance taper.....	See 'Tapers Data Sheet'
Wiper contact resistance.....	Typ. better than 20 dB rel. R
PJ 78 contact resistance (On/Off switch).....	Max. 150 mΩ
PJ 78 insulation resistance.....	Min. 1 MΩ

Potentiometer max. load.....	10 mW
PJ 78 continuous current (On/Off switch).....	500 mA

### Material Specifications

**All materials comply with RoHS directive (2002/95/EC)**



Terminals.....	CuNiZn, gold flash plated
Axle.....	CuNiZn, gold flash plated
Wiper.....	CuNiZn
Knob.....	PA 6.6
Base.....	PES
Carbon track base.....	Glass epoxy composite
Resistance material.....	Carbon/Silver composite

**Lubricant, glue/seal, and paint specifications are proprietary information.**

### Environmental Conditions

Storage temperature ..... -40 to + 60°C  
Storage humidity ..... 10 to 95% RH

### Recommended Process Parameters

#### Mounting:

Fixation nut mounting torque ..... Max. 200 cNcm

#### Soldering:

Soldering temperature and time ..... 300°C [572°F] for 3 s or 350°C [662°F] for 1 s

Soldering distance ..... Min. 0.5 mm [0.02"] from housing  
***To prevent damage to the carbon taper as a result of the soldering process, the knob must be turned either fully CW or CCW.***

***For PJ 78 this must also be opposite to the switch position.***

***Mechanical stress on soldering terminals must be avoided during soldering.***

#### Cleaning:

Cleaning solvents ..... Aqua wash (Alpha 2110), Benzine  
***Ultrasonic cleaning must be avoided as it may remove the lubricant inside the component.***

### Mechanical Dimensions

#### PJ 77

The knob is turned CCW to stop (terminal A).

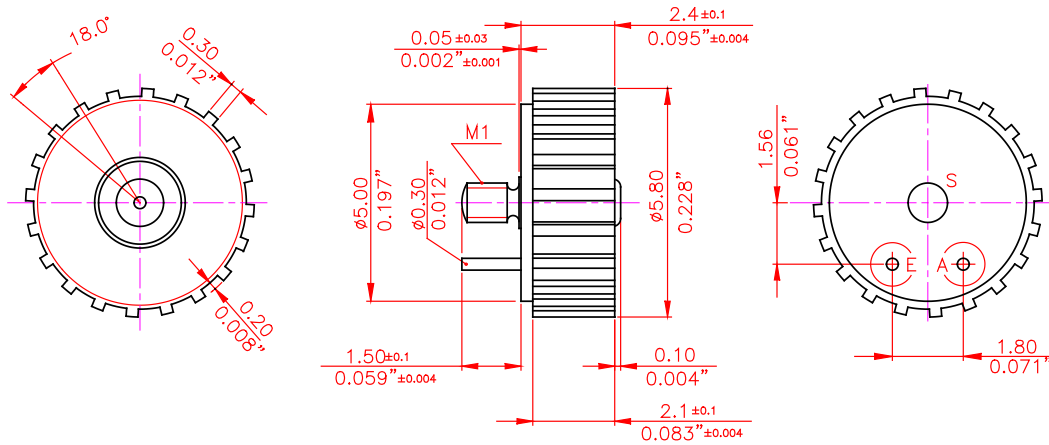

#### PJ 78

The knob is turned CCW to stop (terminal A).

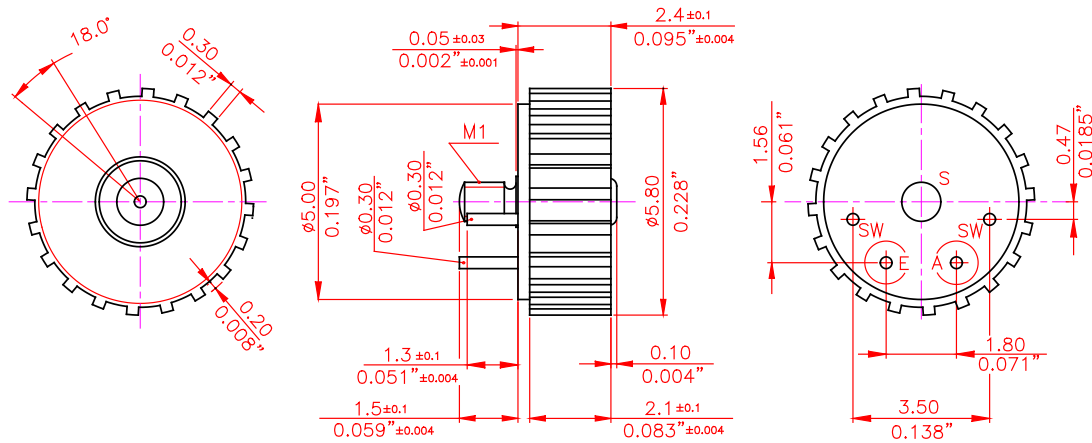

#### Note:

The standard measurement tolerance on the drawings is  $\pm 0.05$  mm/ $[0.002$ "]. Tolerances which differ from this value will be indicated on the drawings.

### Knob Styles

All knobs are shown turned CCW to stop (terminal A)

#### No. 01

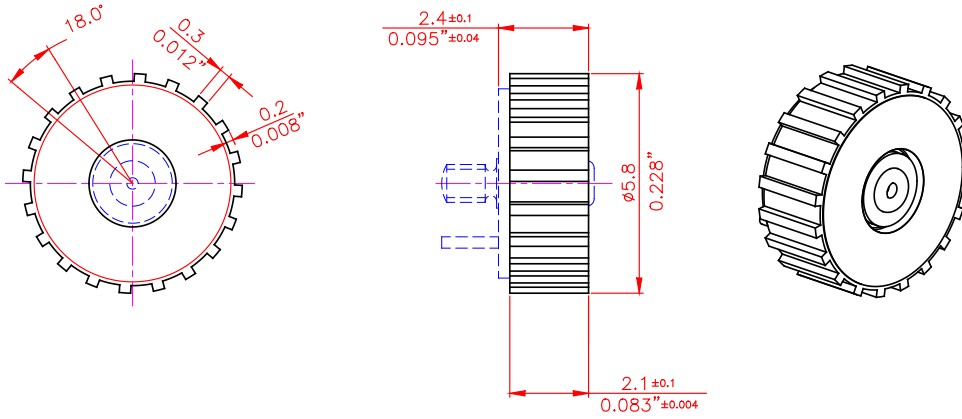

#### No. 02

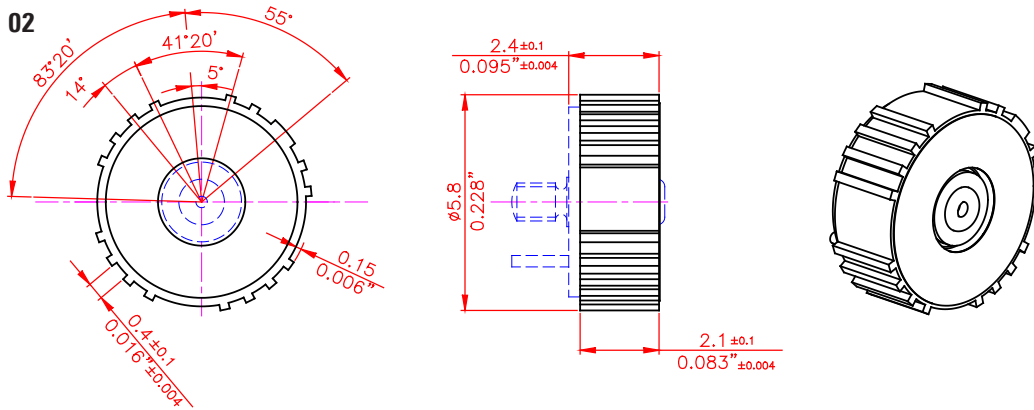

#### No. 11 'Snap-on' knob base. For mounting of caps, shown in the section 'Cap Styles'

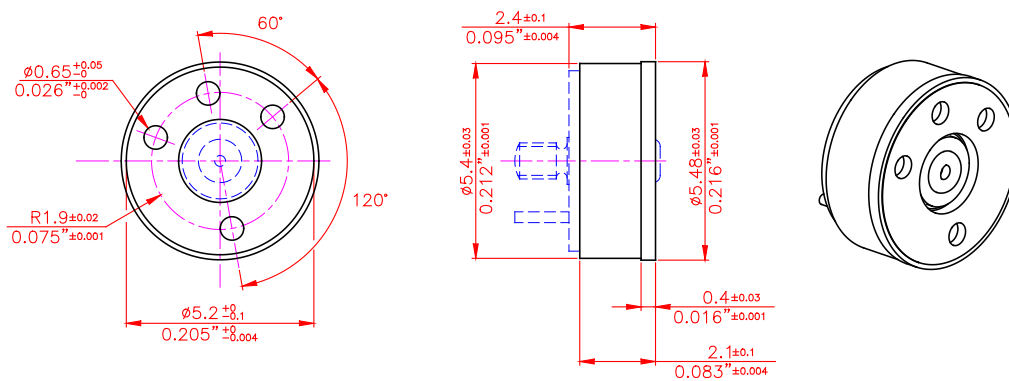

No. 12

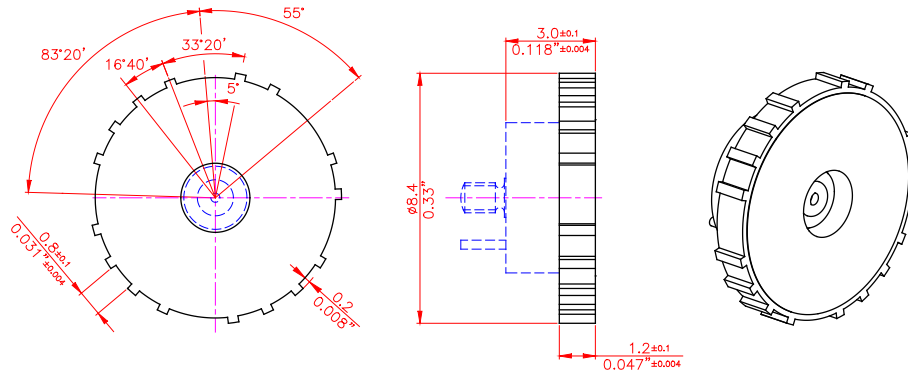

No. 14

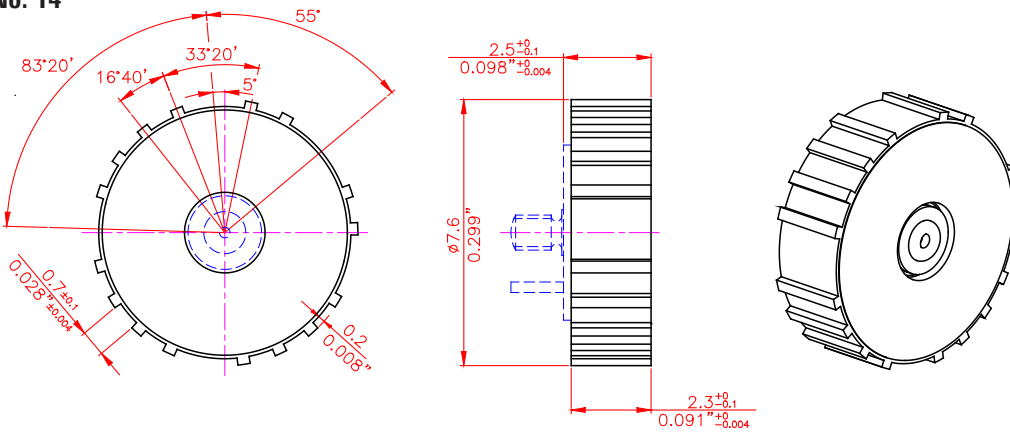

No. 21 'Snap-on' knob base. For mounting of caps, shown in the section 'Cap Styles'

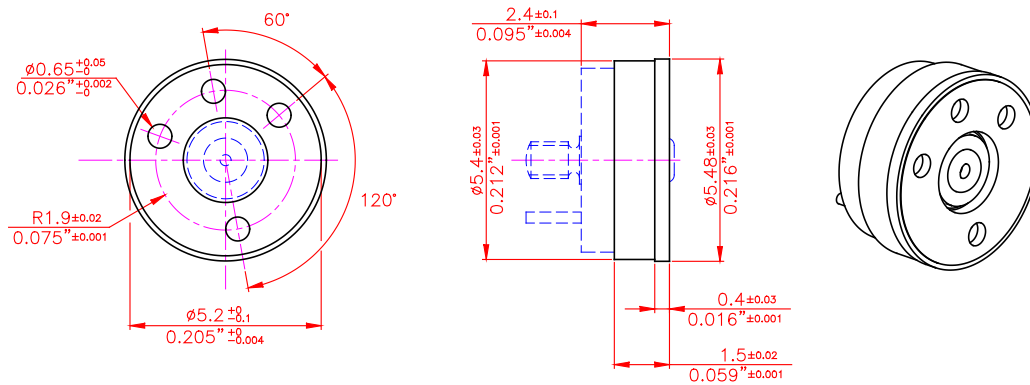

### Knob Prints

The knob is shown turned CCW to stop (terminal A) on all pictures. Available knob print colors: White, black and brown.

No. 01

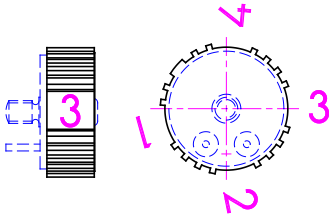

No. 02

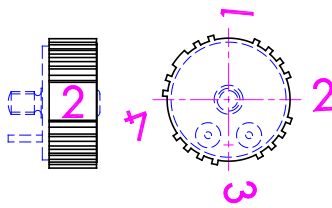

No. 03

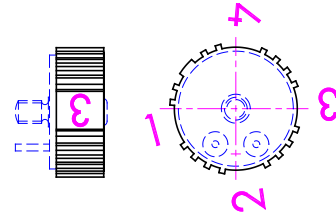

No. 04

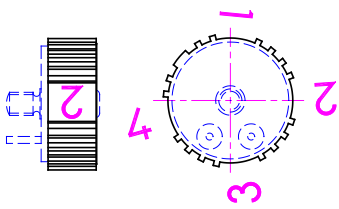

No. 05

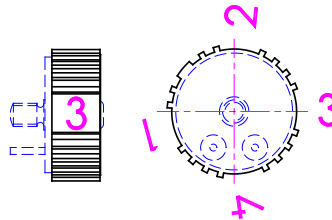

No. 06

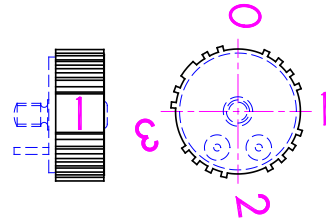

No. 07

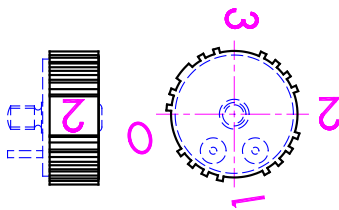

No. 10

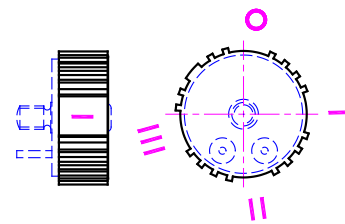

No. 11

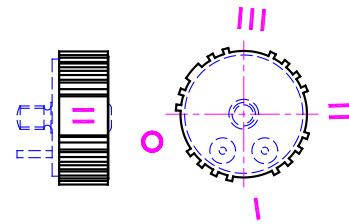

No. 22

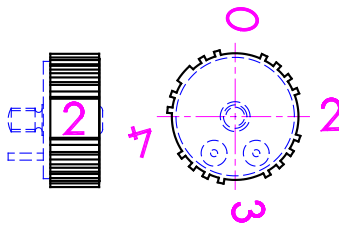

No. 32

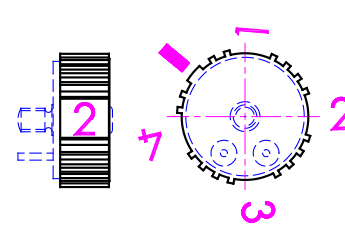

No. 33

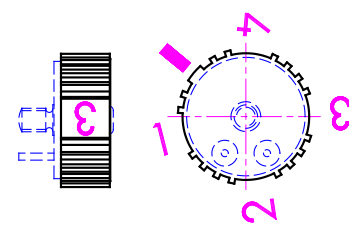

No. 34

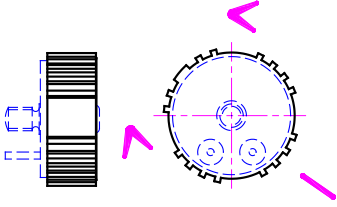

No. 42

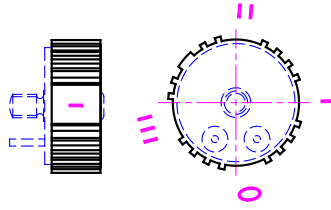

No. 43

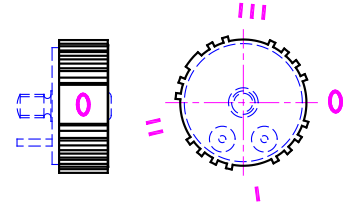

No. 44

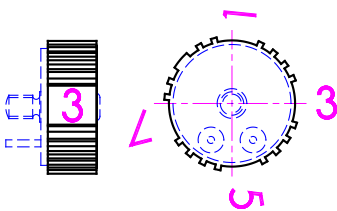

No. 45

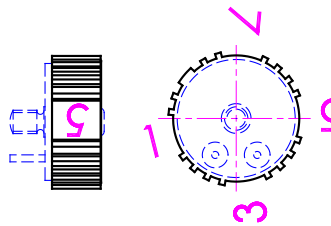

No. 50

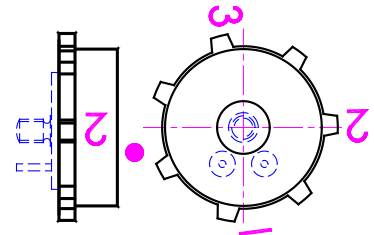

No. 51

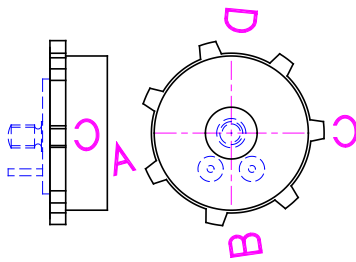

No. 66

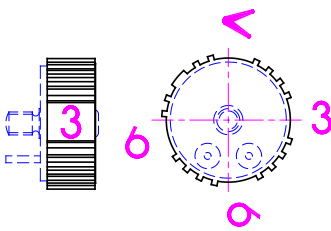

### Cap Styles

Usable for 'Snap-On' knob bases 11 and 21

No. 01

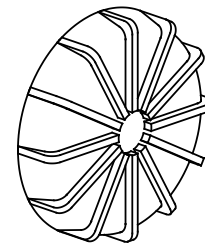
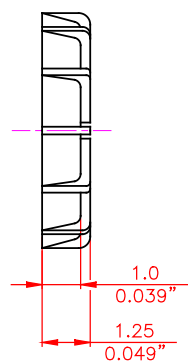
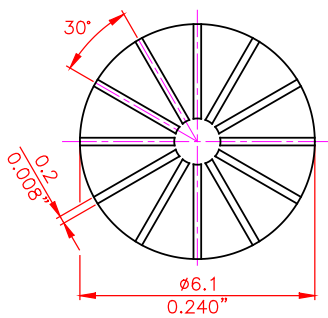

No. 02

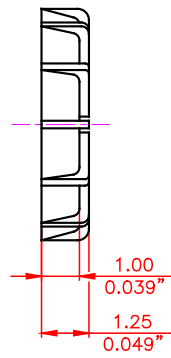
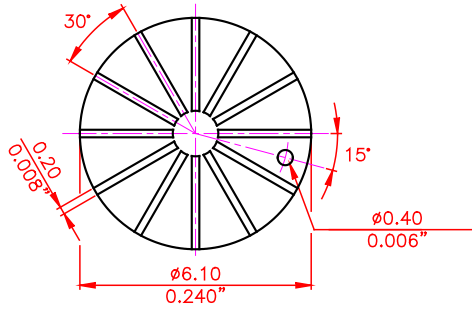

No. 03

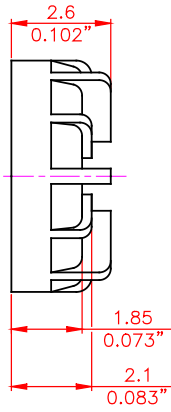
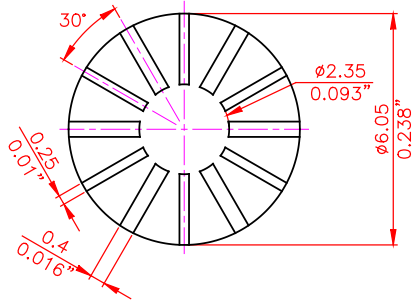

No. 06

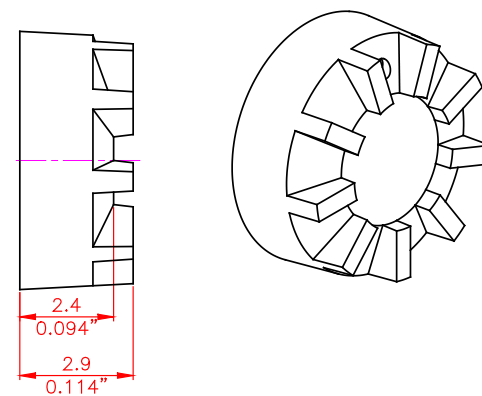
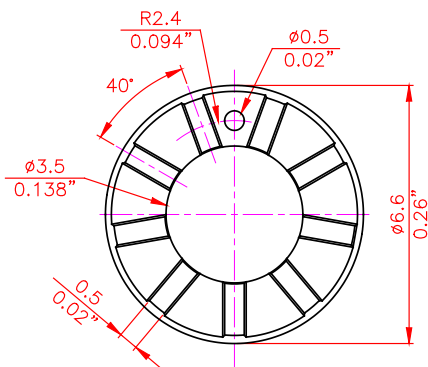

### Axle Styles

No. 01

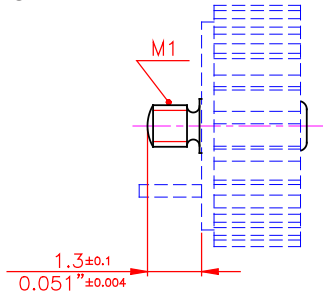

No. 02

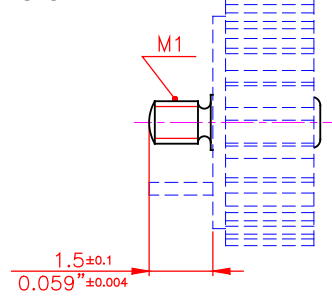

No. 03

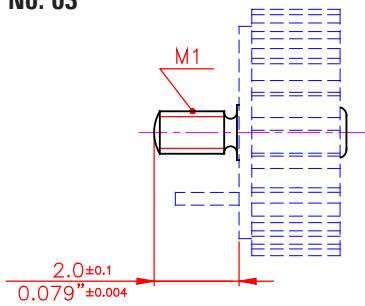

No. 07

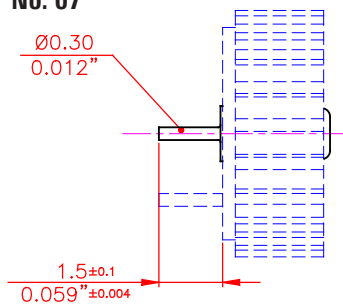

No. 10

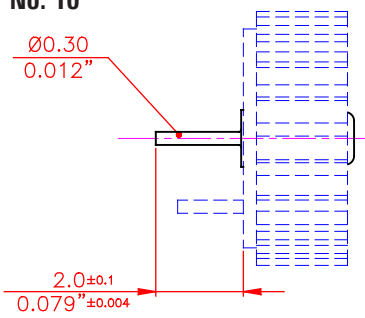

### Terminal Length

No. 01

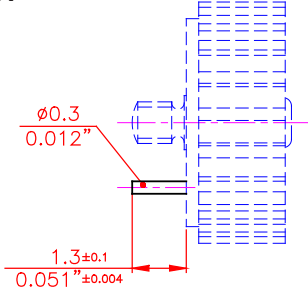

No. 02

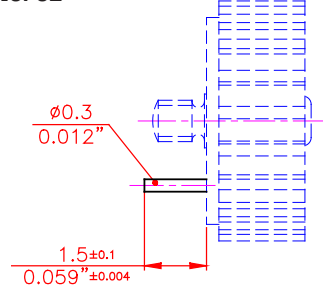

No. 03

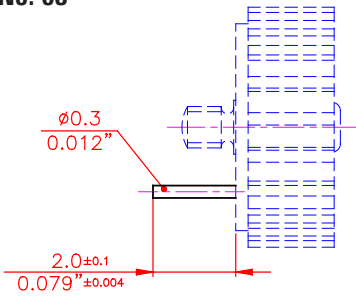

### Adaptor Ring Styles

No. 01

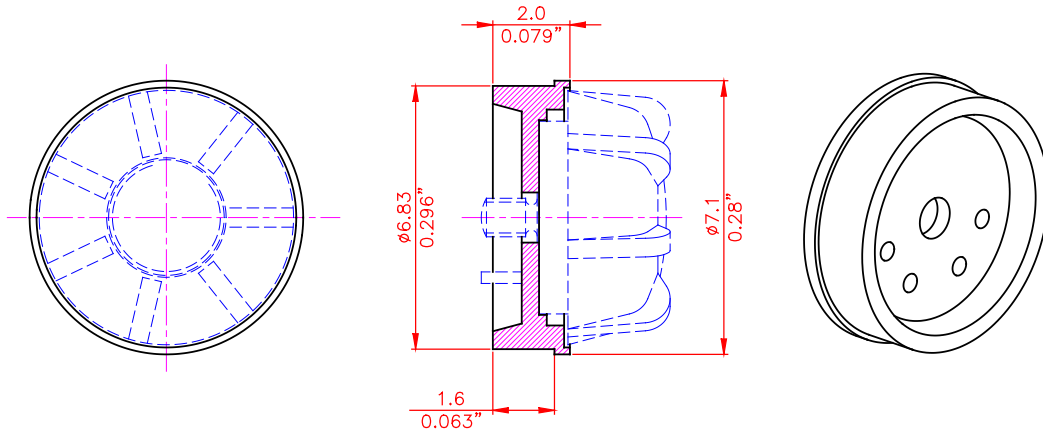

No. 02

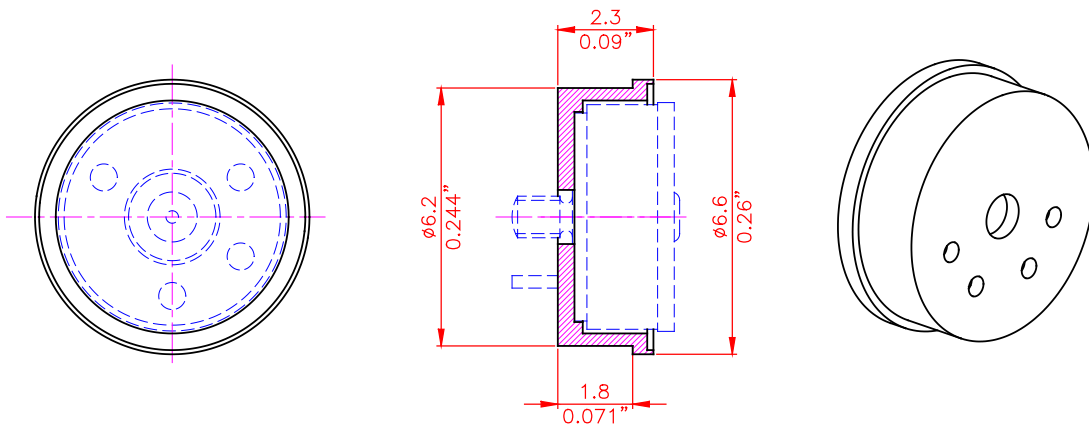

### Plastic Colors

Please refer to the series 200 included in the Sonion 'Plastic Color Assortment' binder.

### Color Coding

Please see colors for coding included in the Sonion 'Plastic Color Assortment' binder.

Please note that all knobs are turned CCW to stop (terminal A) or CW to stop (terminal E).

### Knob

No. 06 CCW

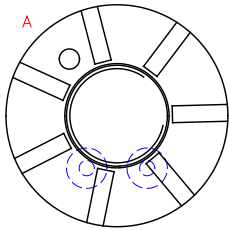

No. 06 CW

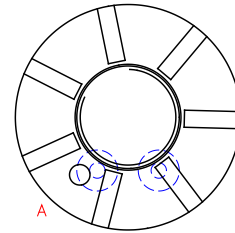

No. 07 CCW

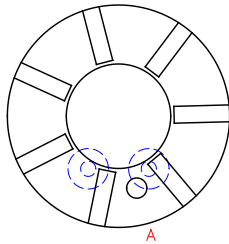

No. 07 CW

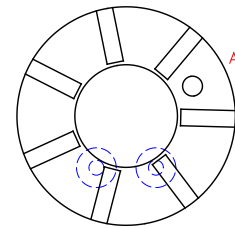

No. 72 CCW

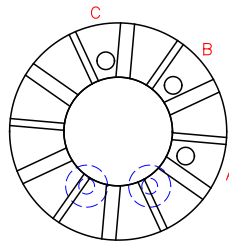

No. 72 CW

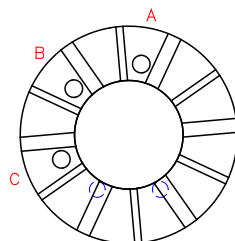

Axle

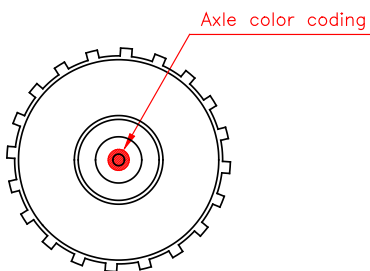

Bottom Color Coding

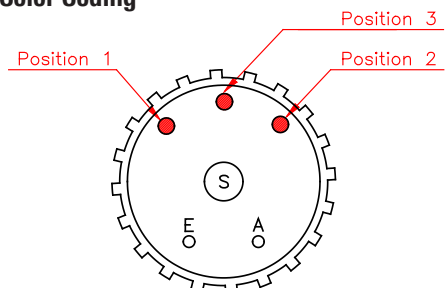

### Product Specification Form

Name: \_\_\_\_\_

Company: \_\_\_\_\_

Customer Part No.: \_\_\_\_\_

Parameters	Look at Page	Enter your choices	Guidelines
Model	1		Please enter PJ 77 or PJ 78 CW or CCW switch
Knob Styles	6-12		
Knob Prints	12-13		Please enter knob print style and knob print color. Available colors: White, brown or black
Cap Styles	14-16		Can only be mounted on 'Snap On' knobs styles nos. 11 and 21.
Axle Styles	16-17		
Adaptor Ring Styles	18		
Plastic Colors	12		Please refer to the series 200 included in the Sonion 'Plastic Color Assortment' binder
Color Coding	19	A B C	Knob Please refer to colors for coding included in the Sonion 'Plastic Color Assortment' binder
			Axle Please refer to colors for coding included in the Sonion 'Plastic Color Assortment' binder
		1 2 3	Bottom Please refer to colors for coding included in the Sonion 'Plastic Color Assortment' binder
Terminal Length	12		
Resistance Value			Please see 'Electrical Specifications' and 'Tapers Data Sheet'
Resistance Taper			Please see 'Electrical Specifications' and 'Tapers Data Sheet'
Accessories			Please see 'Accessories Data Sheet'