

Data Sheet



microphone 8010T

3800 - 3016007
Version:1 20-DEC-2007

Description

The 8000-series microphone has an omni-directional response and can be used in any hearing instrument application. Its unique cylindrical shape offers a flat frequency response while the new integrated circuit meets the increasing electro-acoustic demands. The microphone has low noise, superior EMI suppression, high ESD protection and a short dwell time during soldering.



Features

- Flat Frequency Response
- Ideal For Directional Matching Applications
- Superior EMI Protection
- Optimal Performance At 0.9Vdc
- Excellent Soldering Dwell Time

Dimensions in mm (inch)

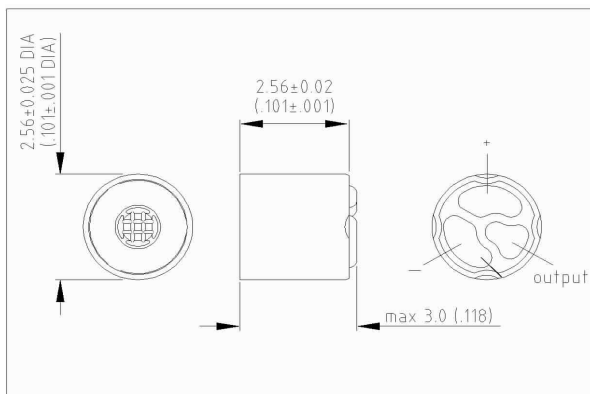

Typical response curve

Refer to specifications section for measurement conditions.

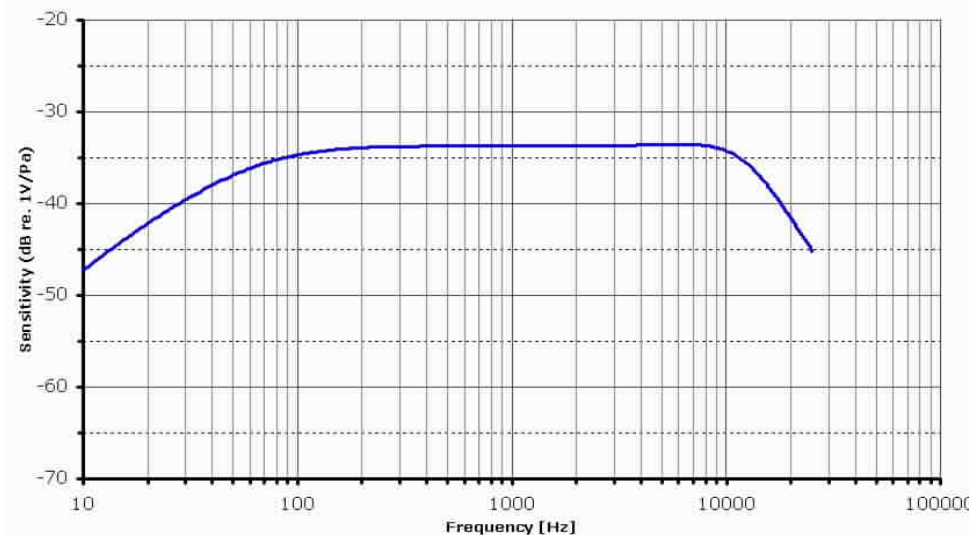

Sonion reserves the right to make changes at any time to improve reliability, function or design, in order to provide the best product possible.

Data Sheet



microphone 8010T

3800 - 3016007
Version:1 20-DEC-2007

Specification

All parameters are specified at 0.9 V and 1 MOhm // <200pF load impedance, AC-coupled with 1µF, unless specified otherwise. Environmental conditions: 23 °C (73.4F), 50 % RH

Parameters		Min	Typ	Max	Unit	Comments
Sensitivity *	@ 50 Hz	-5	-3	-1	dB	re. 1 kHz value
	@ 1 kHz	-36.5	-33.5	-30.5	dB	re. 1V per Pascal
	@ 13 kHz	-5	-2	1	dB	re. 1 kHz value
Peak frequency			-		kHz	
Equivalent noise (A-weighted)			26.5	28	dB SPL	
Power supply feedthrough			-14	-12	dB	
Battery voltage range		0.8	0.9	5	VDC	
Battery drain		10	17	30	µA	
Output impedance **		3	4.5	6	kOhm	
Input-referred vibration sensitivity			66		dB SPL/g	1 kHz ref. acc. in axial direction
Sensitivity change with humidity variation			2	4	dB	30 - 90 % RH
Input-referred EMI noise	0.8-0.96 GHz			30	dB SPL	according SMI 255, E=75 V/m
	1.8-2.0 GHz			30	dB SPL	according SMI 255, E=75 V/m
	1.4-2.0 GHz			40	dB SPL	according SMI 255, E=50 V/m
Operating temperature range		-17	23	63	°C	
Storage temperature range		-40		63	°C	
ESD protection level: Class 2 according to MIL-STD-750D, test method 1020,2. Apply protection in accordance with IEC 61340-5-1 and 61340-5-2.						
* 1 kHz sensitivity at 1.3 VDC supply: -32.5 dB re. 1V/Pa typ.						
** Output impedance at 1.3 VDC supply: 3 kOhm typ.						

Typical 1/3 octave equivalent noise

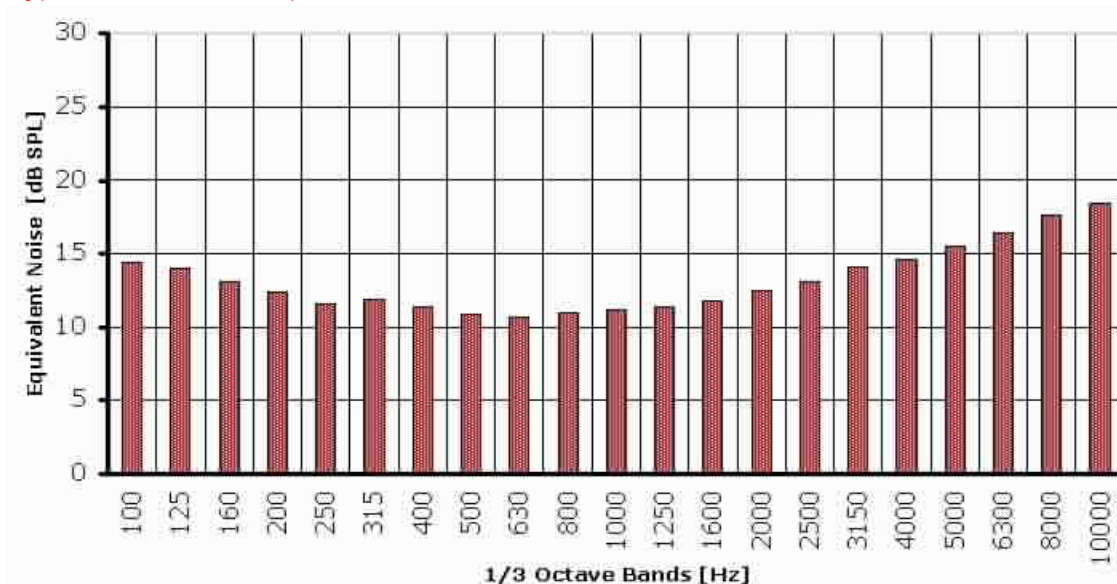

Sonion reserves the right to make changes at any time to improve reliability, function or design, in order to provide the best product possible.